

Driver Unit type SRB 3103

Manual

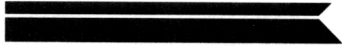



Contents	Page
Description	2
Principle of operation	2
Function description	
• separate start and stop signals	3
• single signal source	3
Valve driver output	3
PNP/NPN signal sources	3
Application example 1	4
Application example 2	4
Mounting	5
Ordering	6
Technical data	6

About this manual

This manual is intended for construction personnel and anyone else who may require technical information about the SRB 3103 driver unit.

The terminal designation is written in *Italics>*.

Description



Fig. 1

The SRB 3103 driver unit is designed for driving the *RotaStep* clutch/brake unit of the Danfoss Precision Step Systems.

The features include:

- Separate level controlled start and stop inputs
- Adaptable to NPN or PNP signal sources

The SRB 3103 is used as link between an electronic control system, for example a PLC, and the *RotaStep* clutch/brake unit.

Principle of operation

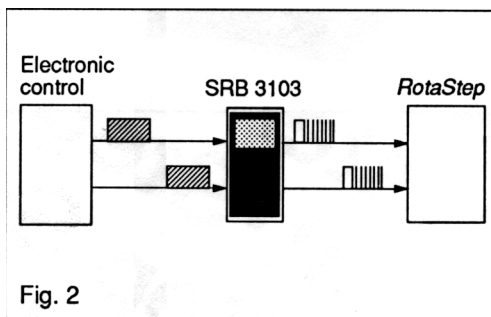
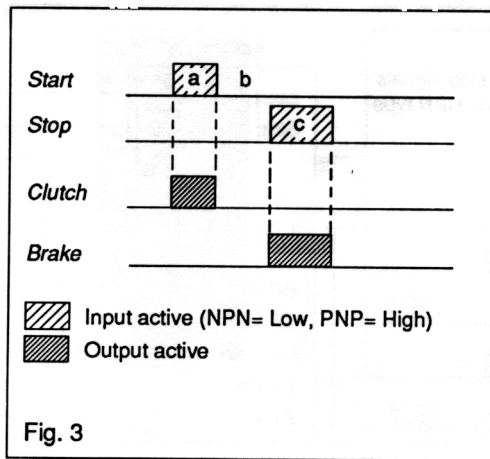

Fig. 2

The solenoid valves of the *RotaStep* require a special voltage signal. The SRB 3103 converts logic signals to valve driver signals.

Function description



Separate start and stop signals

- a. When a signal is supplied at *Start*, the *Clutch* output is switched on. Clutch mode is only on as long as the *Start* input is active.
- b. When no signal is given to either of the inputs, the *RotaStep* unit is in free mode, allowing both input and output shaft to rotate freely.
- c. When a signal is supplied at *Stop*, the *Brake* output is switched on. Brake mode is only on as long as the *Stop* input is active.

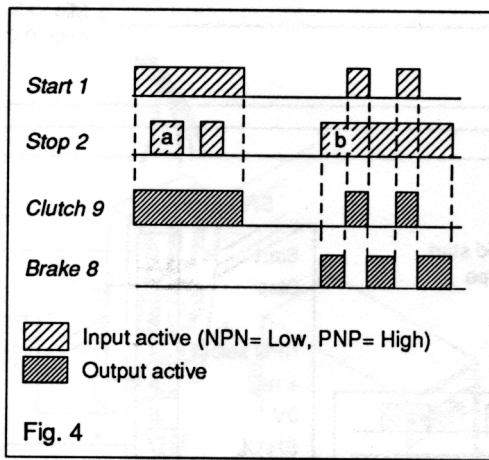

Single signal source

- a. Due to the higher priority of the *Start* input, activation of the *Stop* input has no effect while the *Start* input is active.
- b. A single signal mode is obtained by keeping the *Stop* input constantly active and switching the *Start* input on and off alternately.

Valve driver output

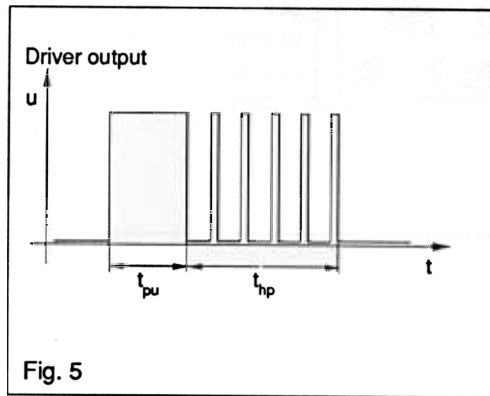

The solenoid valve driver output consists of a pick-up pulse t_{pu} and a holding period t_{hp} . The pick-up pulse ensures fast activation of the solenoid valves.

During the holding period, the valve output voltage is chopped to decrease the current. This minimizes heat dissipation in the solenoid coils.

PNP/NPN signal sources

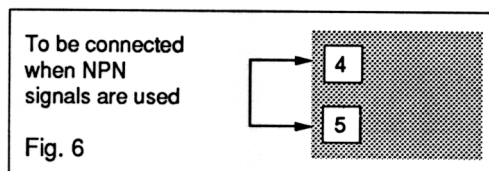

The SRB 3103 is factory set to respond to PNP signals. If NPN signals are used, the terminals 4 and 5 must be connected by a jumper.

Application example 1

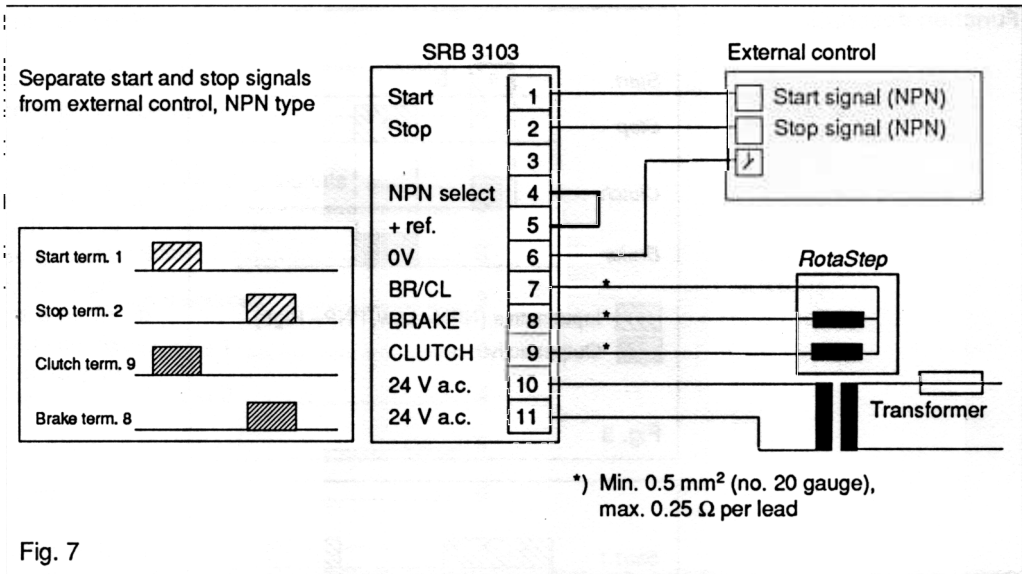

Application example 2

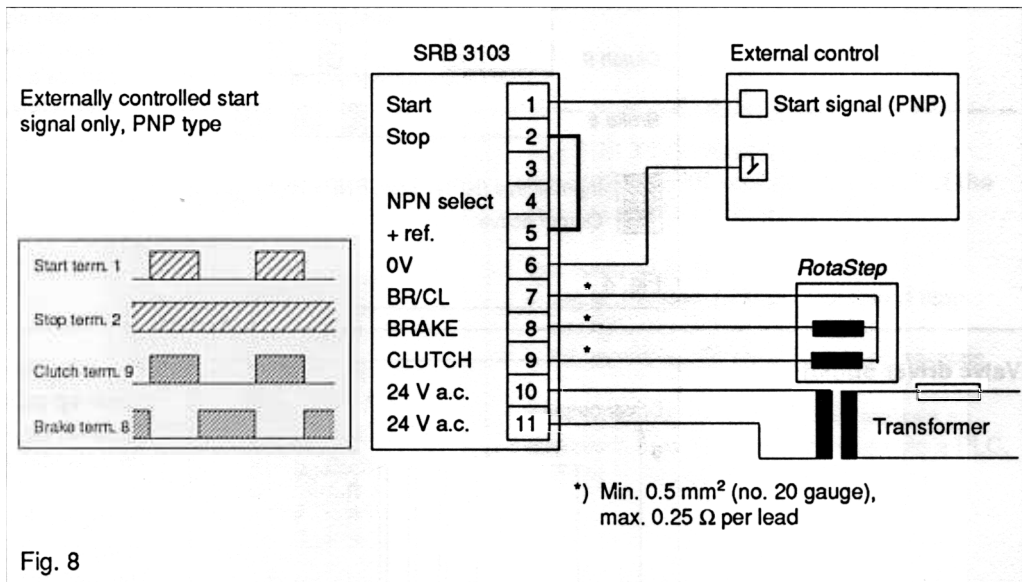

Mounting

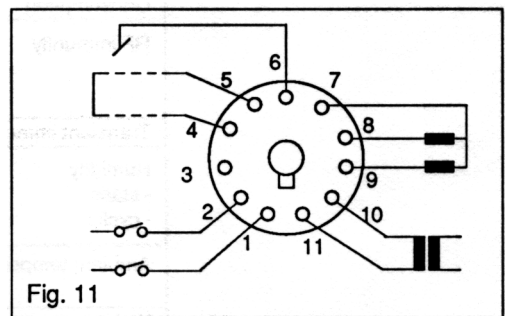
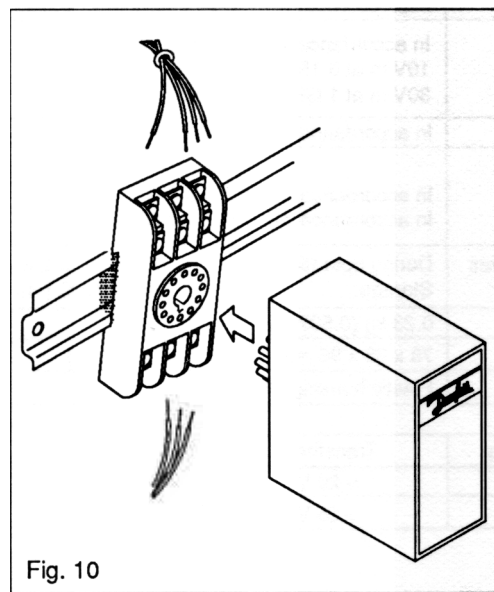
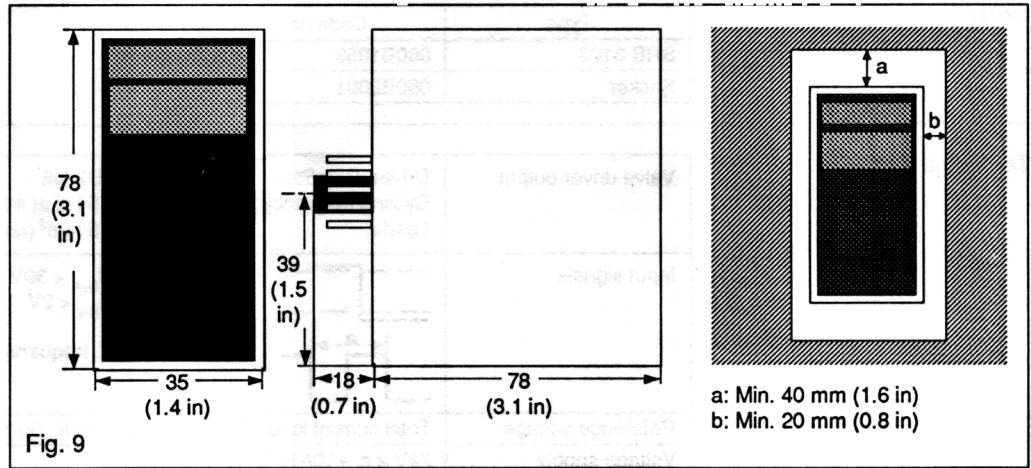

Terminal	Function
1	Start
2	Stop
3	Not used
4	NPN select (when NPN source)
5	+ reference (max. 10 mA)
6	0V
7	BR/CL, valve common Do not connect to ground or earth
8	Brake output
9	Clutch output
10	24V a.c. supply
11	24V a.c. supply

Ordering

Type	Code no.
SRB 3103	080B1053
Socket	080B2091

Technical data

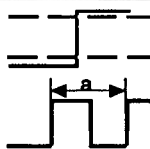
Valve driver output	Drives <i>RotaStep</i> : Cycling frequency: Leads:	06-15/U2-U6 Max. 15 Hz at 40°C (104°F) ambient temperature Min. 0.5 mm ² (no. 20 gauge), max. 0.25 Ω
Input signals		$8V < U_{high} < 30V$ $0V \leq U_{low} < 2V$ a: Max. frequency 15 Hz
Reference voltage	Total current load:	Max. 10mA. Do not use as supply
Voltage supply	24V a.c. +10/-15% *)	
Consumption	Max. 25 W	
RF immunity	In accordance with DS 5106 p2: 10V/m at 0.15 MHz - 1GHz 30V/m at 1 GHz - 12 GHz	
Transient immunity	In accordance with SS436 1503 part 3	
Humidity - static - cyclic	In accordance with IEC 68-2-3 Ca In accordance with IEC 68-2-30 Db	
Ambient temperatures	During operation: Storage:	0 to 40°C (32 to 104°F) -40 to 70°C (-40 to 160°F)
Weight	0.23 kg (0.507 lb)	
Dimensions	78 x 38 x 96 mm (3.07 x 1.35 x 3.78 in)	
Enclosure	Plastic housing, IP42 (NEMA 11)	

*)

Cycling frequency	Transformer
1-10 Hz	> 20 VA
15 Hz	> 25 VA