

1

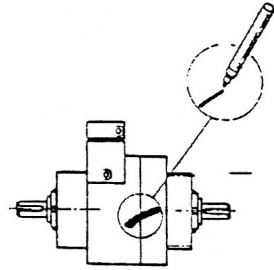

2

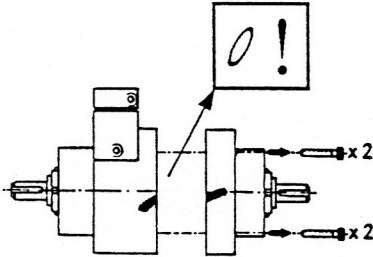

3

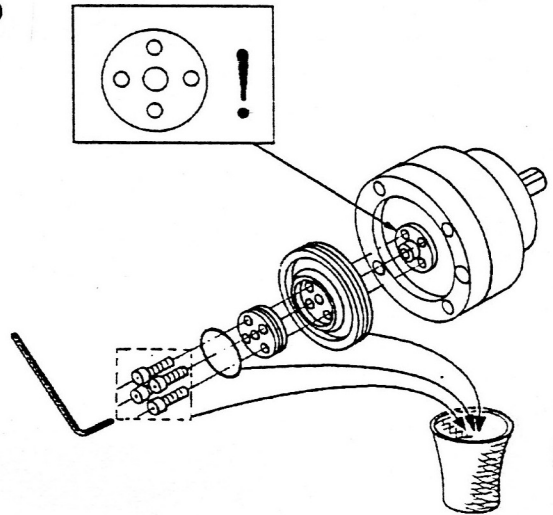

4

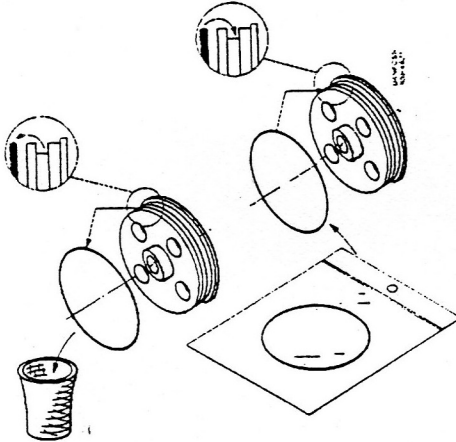

5

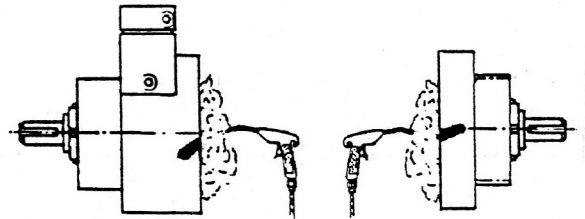

6

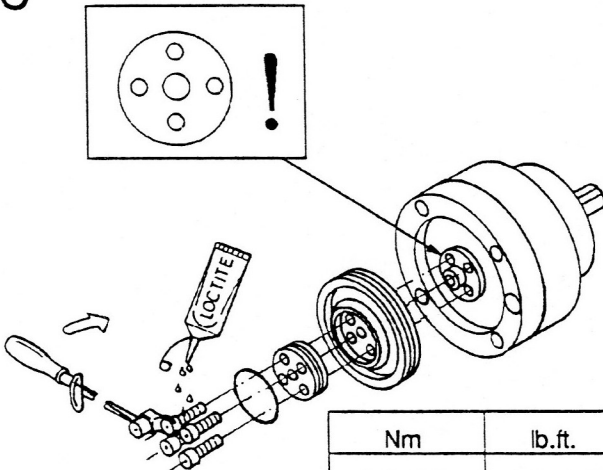

| Nm | lb.ft. |
|-----------|-----------|
| 2.2 - 2.5 | 1.6 - 1.8 |

7

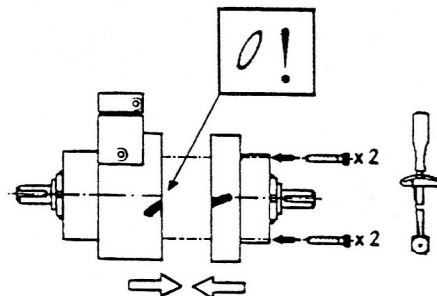

| Nm | lb.ft. |
|-------|-----------|
| 6 - 8 | 4.4 - 5.9 |



INSTRUCTIONS

RotaStep Service Kit

Friction Disc 080H015X

| | Service Kit |
|----------------|-------------|
| RotaStep 08/U3 | 080H0151 |
| RotaStep 10/U4 | 080H0152 |
| RotaStep 12/U5 | 080H0153 |
| RotaStep 15/U6 | 080H0154 |

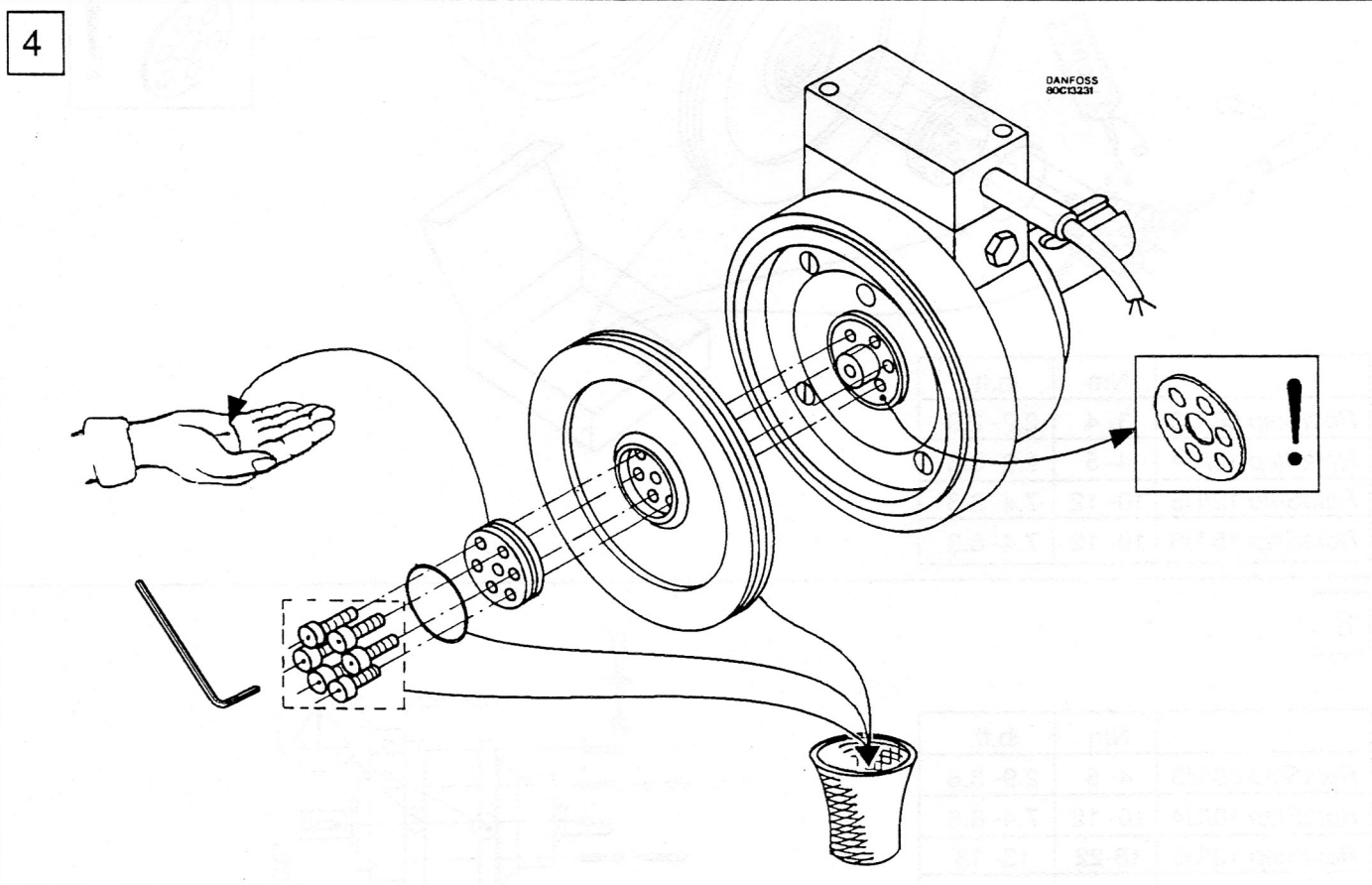
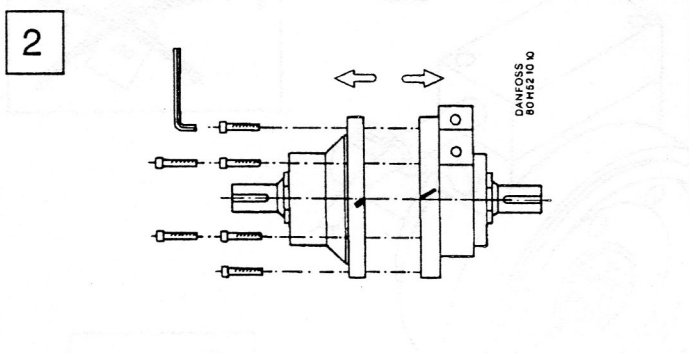
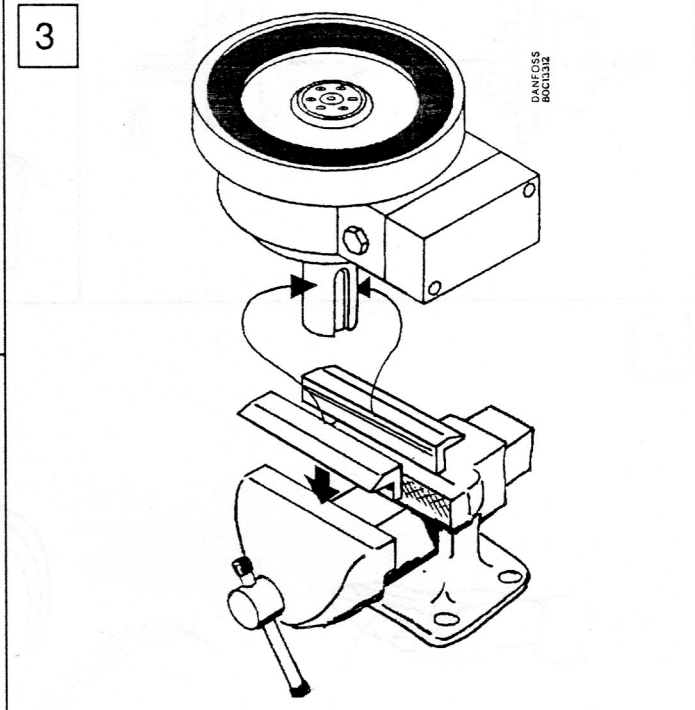
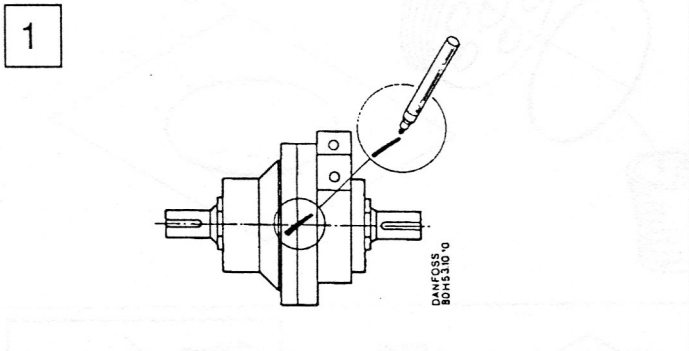
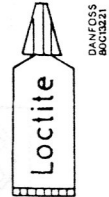
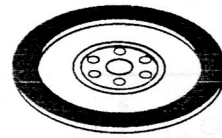
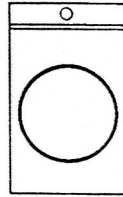
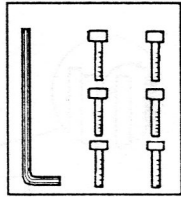

5

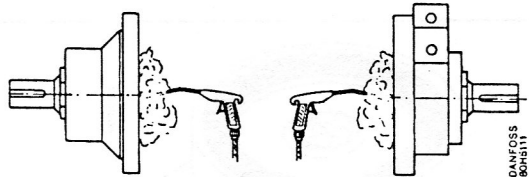
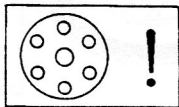
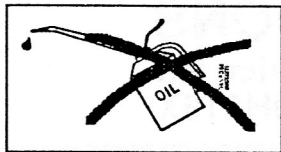

6

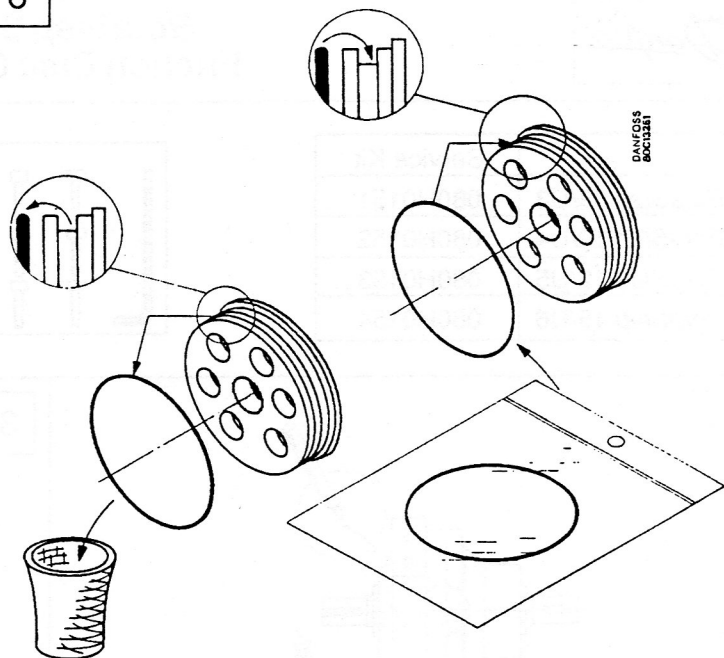

7

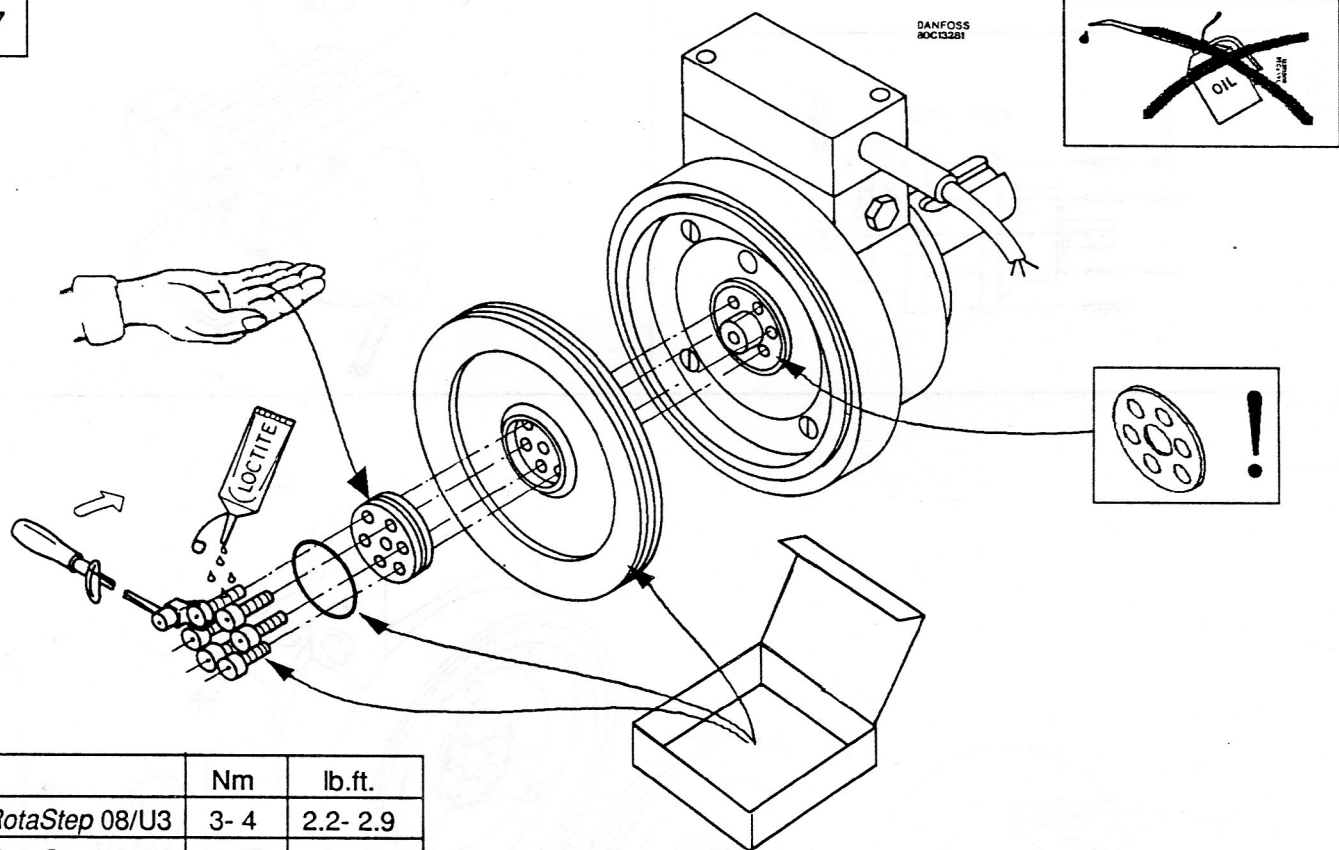

| | Nm | lb.ft. |
|-----------------------|--------|----------|
| <i>RotaStep 08/U3</i> | 3- 4 | 2.2- 2.9 |
| <i>RotaStep 10/U4</i> | 4- 5 | 2.9- 3.6 |
| <i>RotaStep 12/U5</i> | 10- 12 | 7.4- 8.8 |
| <i>RotaStep 15/U6</i> | 10- 12 | 7.4- 8.8 |

8

| | Nm | lb.ft. |
|-----------------------|--------|----------|
| <i>RotaStep 08/U3</i> | 4- 5 | 2.9- 3.6 |
| <i>RotaStep 10/U4</i> | 10- 12 | 7.4- 8.8 |
| <i>RotaStep 12/U5</i> | 18-22 | 13- 16 |
| <i>RotaStep 15/U6</i> | 18-22 | 13- 16 |

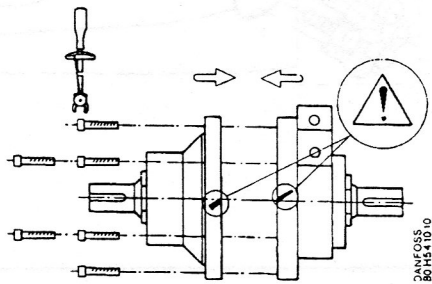



INSTRUCTIONS

RotaStep Service Kit Valve Unit 080H011X

| | |
|---------------------------------|-------------|
| <i>RotaStep</i> | Service Kit |
| 06, 08, 10, 12, U2, U3, U4, U5, | 080H0118 |
| 15, U6 | 080H0119 |

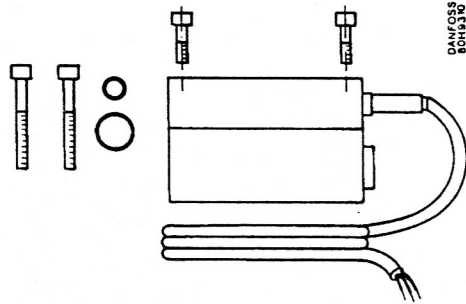

1

DANFOSS 80H48.12

3

| | |
|---------|---------|
| Nm | lb.ft |
| 1.5-2.5 | 1.1-1.8 |

| | |
|-----|---------|
| Nm | lb.ft |
| 5-7 | 3.7-5.2 |

DANFOSS 80H48.13

2

DANFOSS 80H47.10

4

| | |
|--------|---|
| SRB | |
| BRAKE | A |
| BR/CL | B |
| CLUTCH | C |

A: Sort, black, schwarz, noir, negro, nero, svart, zwart, 黑
 B: Brun, brown, braun, brun, marron, bruno, brun, bruin, 茶
 C: Blá, blue, blau, bleu, azul, blu, blá, blauw, 青

080R9162

080R9162

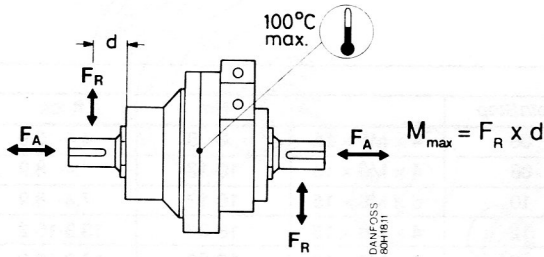
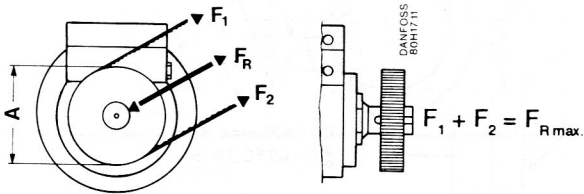
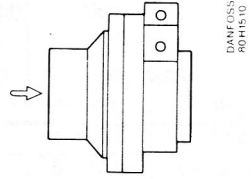
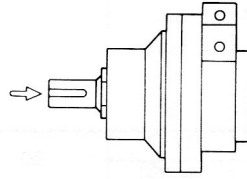
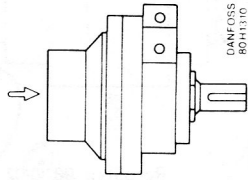
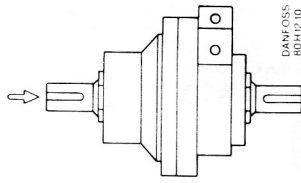

| RotaStep | F_A [N] | F_{Rmax} [N] | M_{max} [Nm] | A_{min} [mm] |
|----------|-----------|----------------|----------------|----------------|
| 06 | 300 | 300 | 10 | 50 |
| 08 | 400 | 400 | 20 | 90 |
| 10 | 600 | 700 | 25 | 100 |
| 12 | 800 | 1000 | 40 | 130 |
| 15 | 800 | 1000 | 40 | 240 |

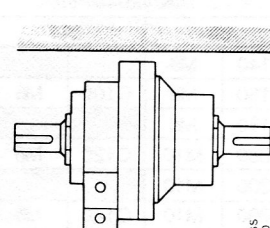
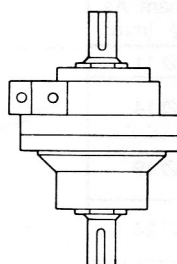
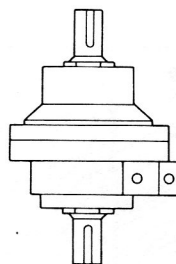
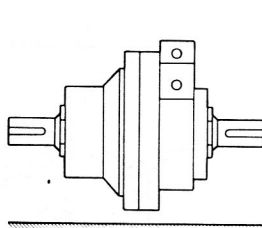
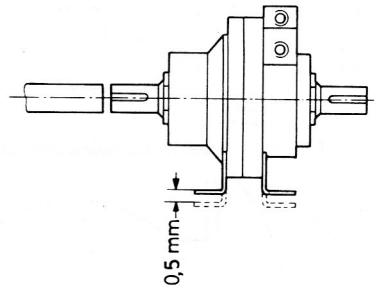
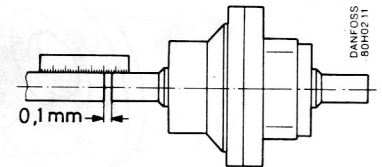
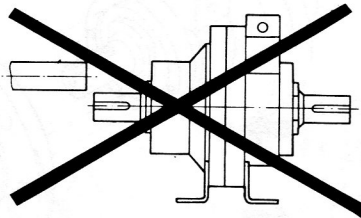
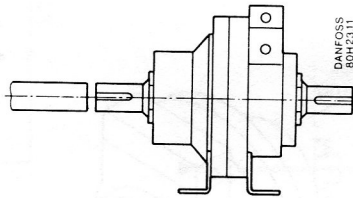
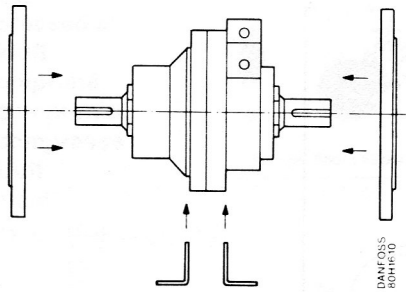

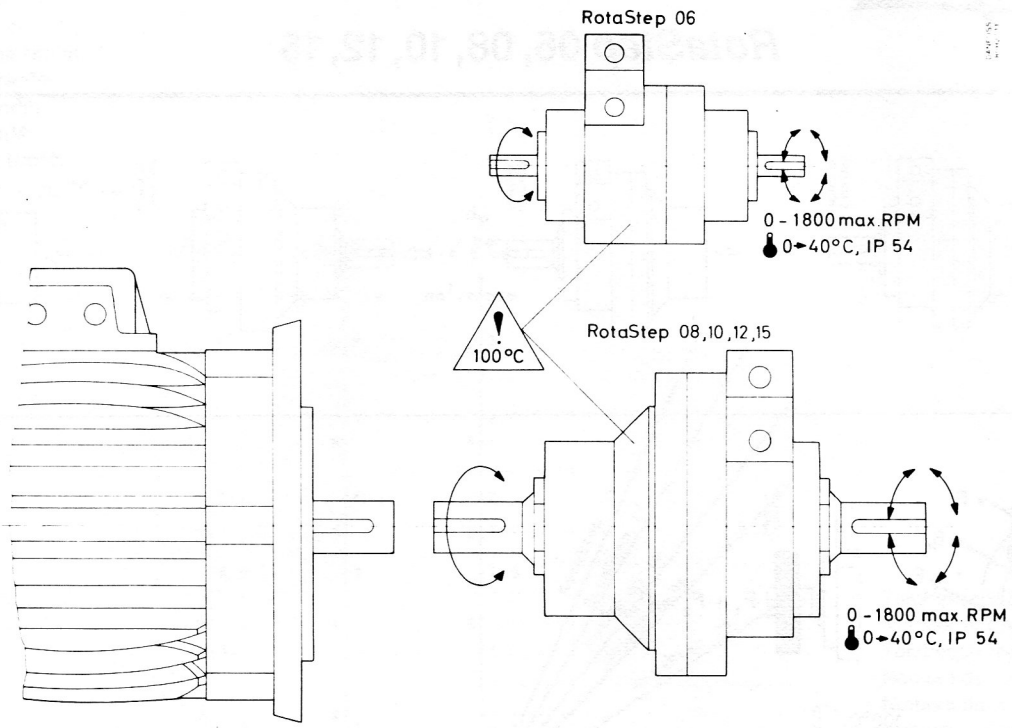

| RotaStep | | Nm | ft-lbs |
|----------|-------------|-------|-----------|
| 06 | 4 × M5 × 15 | 6- 8 | 4.4- 5.9 |
| 08 | 4 × M6 × 15 | 10-12 | 7.4- 8.9 |
| 10 | 6 × M6 × 15 | 10-12 | 7.4- 8.9 |
| 12 | 4 × M8 × 15 | 18-22 | 13.3-16.2 |
| 15 | 4 × M8 × 15 | 18-22 | 13.3-16.2 |

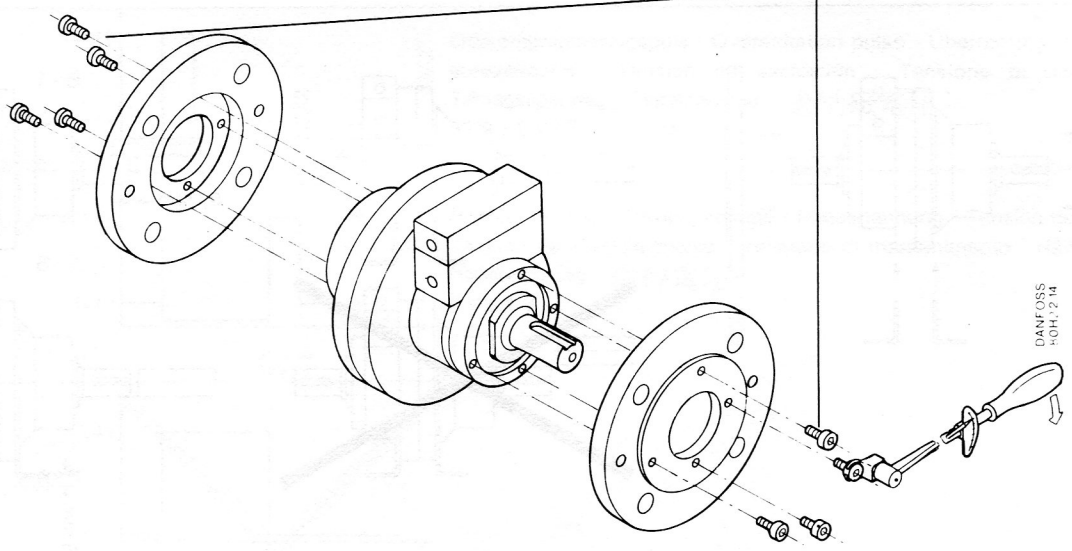

| RotaStep | Flange, Flansch, Flasque, Brida, Flangia, Fläns, Flens, フランジ | | | | Aksel, Shaft, Welle, Arbte, Eje, Albero, Axeldiam, As, 軸径 [mm] |
|----------|--|-----|------|----|--|
| | DIN 42948 | | | | |
| | B5 | | B14 | | |
| 06 | A140 | M8 | | | ∅ 11 |
| | A160 | M8 | C105 | M6 | ∅ 14 |
| 08 | A160 | M8 | | | |
| | A200 | M10 | C120 | M6 | ∅ 19 |
| 10 | A200 | M10 | | | |
| | A200 | M10 | C140 | M8 | ∅ 24 |
| 12/15 | A200 | M10 | | | |
| | A250 | M12 | C160 | M8 | ∅ 28 |

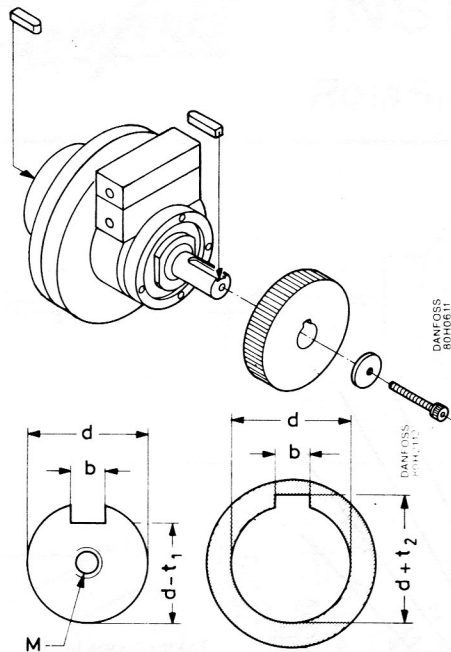

| RotaStep | Aksel Shaft Welle Arbre Eje Albero Axeldiam. As 軸径 | Gevindhul Threaded hole Schraubengew. Trou taraudé Taladro rosc. Foro filettato Gångat hål Asbor. (getapt) ネジ穴寸法 | Notgang Keyway Passfedernut Clavette Chavetero Chiavetta Plattkil Geveerde spie キー溝 | |
|----------|--|--|---|----------------------|
| | d | M | b × d-t ₁ | b × d-t ₂ |
| 06 | ∅ 11 | M4 × 10 | 4 × 8.5 | 4 × 12.8 |
| | ∅ 14 | M5 × 10 | 5 × 10.95 | 5 × 16.35 |
| 08 | ∅ 14 | M5 × 10 | 5 × 10.95 | 5 × 16.35 |
| | ∅ 19 | M5 × 12 | 6 × 15.5 | 6 × 21.8 |
| 10 | ∅ 19 | M5 × 12 | 6 × 15.5 | 6 × 21.8 |
| | ∅ 24 | M6 × 16 | 8 × 19.9 | 8 × 27.4 |
| 12 | ∅ 24 | M6 × 16 | 8 × 19.9 | 8 × 27.4 |
| | ∅ 28 | M6 × 16 | 8 × 24 | 8 × 31.3 |
| 15 | ∅ 24 | M6 × 16 | 8 × 19.9 | 8 × 19.9 |
| | ∅ 28 | M6 × 16 | 8 × 24 | 8 × 31.3 |

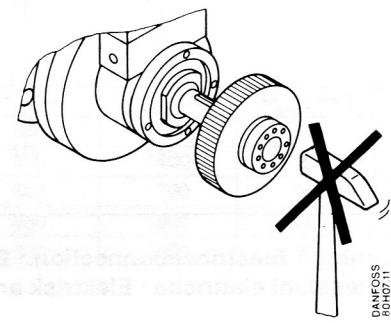
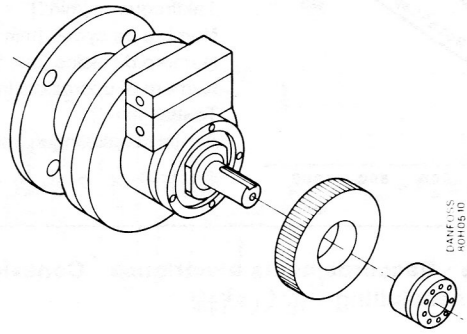

Trykluft
Compressed air
Druckluft
Air comprimé
Aire comprimido
Aria compressa
Tryckluft
Perslucht

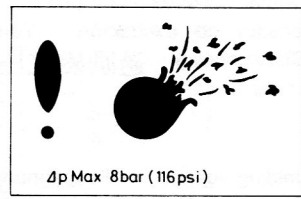

コンプレッサーエア

Filter
Filtre
Filtro
フィルターサイズ

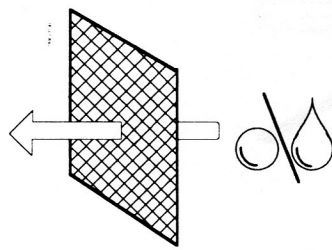

Max. ∅ 0.01 μm
≈ 0.01 ppm

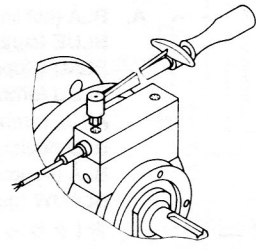
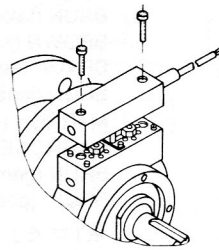
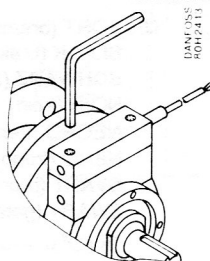
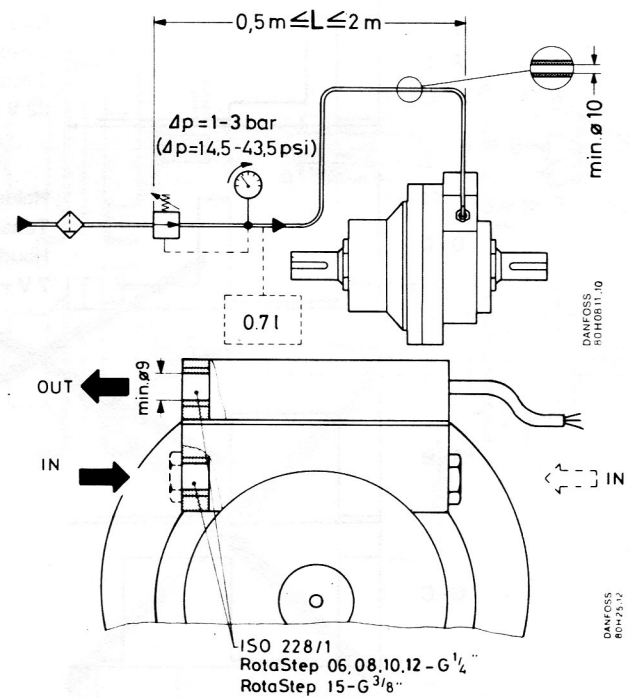

| N _m | ft-lbs |
|----------------|---------|
| 1.5-2.5 | 1.1-1.8 |

Luftforbrug Nm³/h
 Air consumption Nm³/h
 Luftverbrauch Nm³/h
 Consommation d'air Nm³/h
 Consumo de aire Nm³/h
 Consumo d'aria Nm³/h
 Luftförbrukning Nm³/h
 Perslucht verbruik Nm³/h
 コンプレッサ・エアー
 消費量Nm³/h

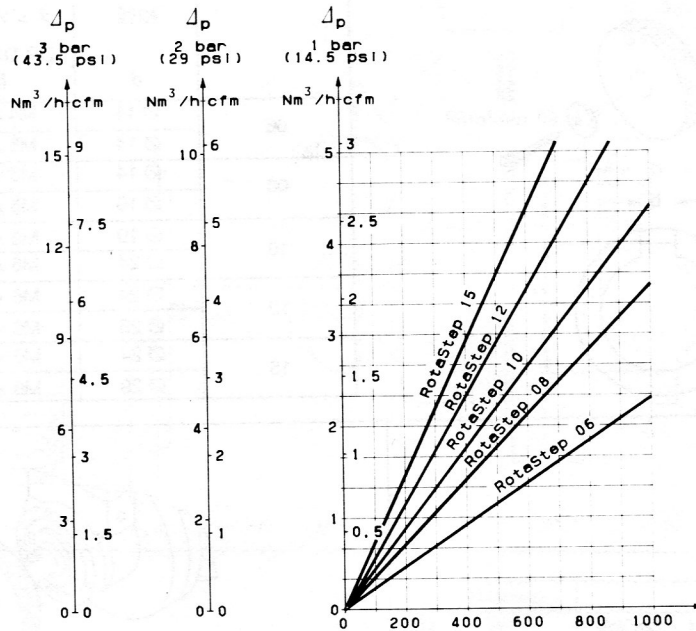

Elektrisk tilslutning · Electrical connection · Elektrischer Anschluss · Raccordements électriques · Conexiónado eléctrico · Conessioni elettriche · Elektrisk anslutning · Elektrische aansluiting · 電気結線

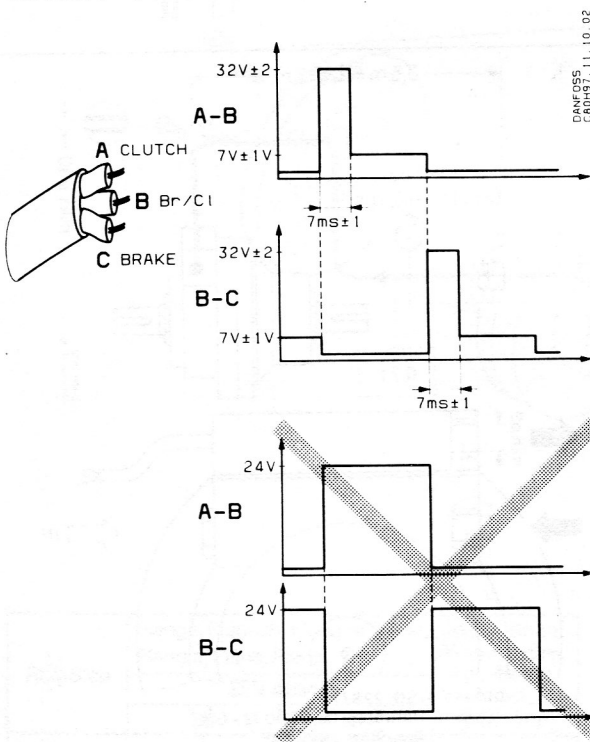

Overmagnetiseringspuls · Overexcitation pulse · Überregung · Tension de surexcitation · Tensión de excitación · Tensione di eccitazione ·
 Tillslagsspänning · Startspanning · 過励磁電圧 :
 32 V ± 2 V / 7 ms ± 1 ms

Holdespænding · Holding voltage · Haltespannung · Tension de maintien ·
 Tensión de mantenimiento · Tensione di mantenimento · Hållspänning ·
 Houdspanning · 保持電圧 :
 7 V ± 1 V

Trykluft:
 Compressed air:
 Druckluft:
 Air comprimé:
 Aire comprimido:
 Aria compressa:
 Tryckluft:
 Perslucht:
 コンプレッサ・エアー:

A. BLÅ (kobling)
 BLUE (clutch)
 BLAU (Kupplung)
 BLEU (embrayage)
 AZUL (embrague)
 BLU (frizione)
 BLÅ (koppling)
 BLAUW (gekoppeld)
 青(クラッチ)

B. BRUN (fælles)
 BROWN (junction)
 BRAUN (gemeins. Leiter)
 BRUN (jonction)
 MARRON (comun)
 MARRONE (collegamento)
 BRUN (gemensam)
 BRUIN (gezamenlijke klem)
 茶(コモン)

C. SORT (bremse)
 BLACK (brake)
 SCHWARZ (Bremse)
 NOIR (frein)
 NEGRO (freno)
 NERO (freno)
 SVART (broms)
 ZWART (geremd)
 黒(ブレーキ)